

Grade 7

One-Point
Perspective
Drawing

To All of My Students:

I hope you are all doing well and staying healthy. Please read through this PDF for instructions on how to get started on this project. Remember to practice these techniques until you are comfortable before you start your good copy. Take your time and have fun.

- Ms. Tai

Project Overview

- Students will create a linear perspective drawing using one-point perspective drawing to create the illusion of depth and space in their drawing. Students will draw a street with buildings.



What You Will Need:

- Pencil
- Eraser
- Ruler
- Variety of colouring mediums (Colouring pencils, Markers, etc.)
-Optional
- Quality Drawing paper (Blank paper is fine)

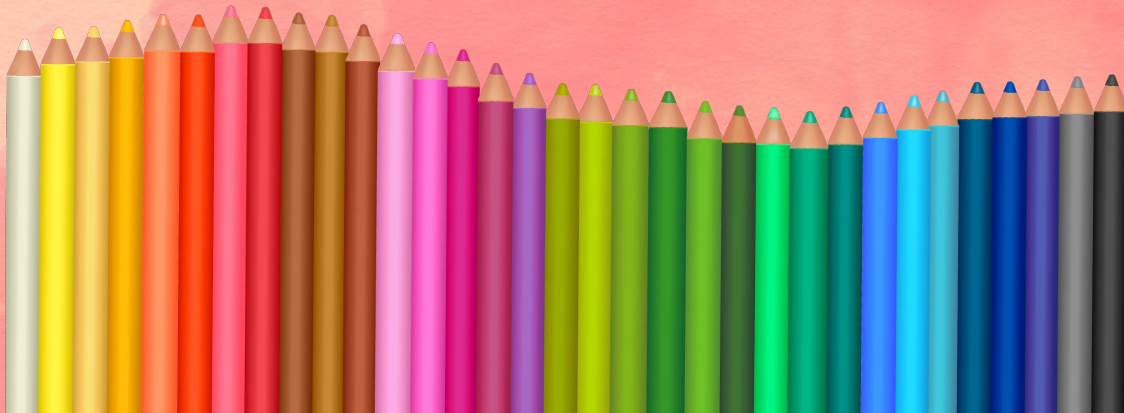
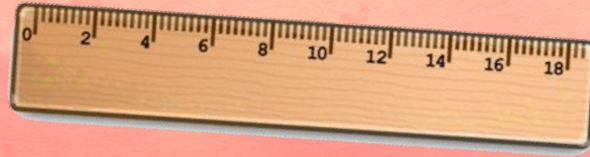

Practice/Rough Copy



Step 1

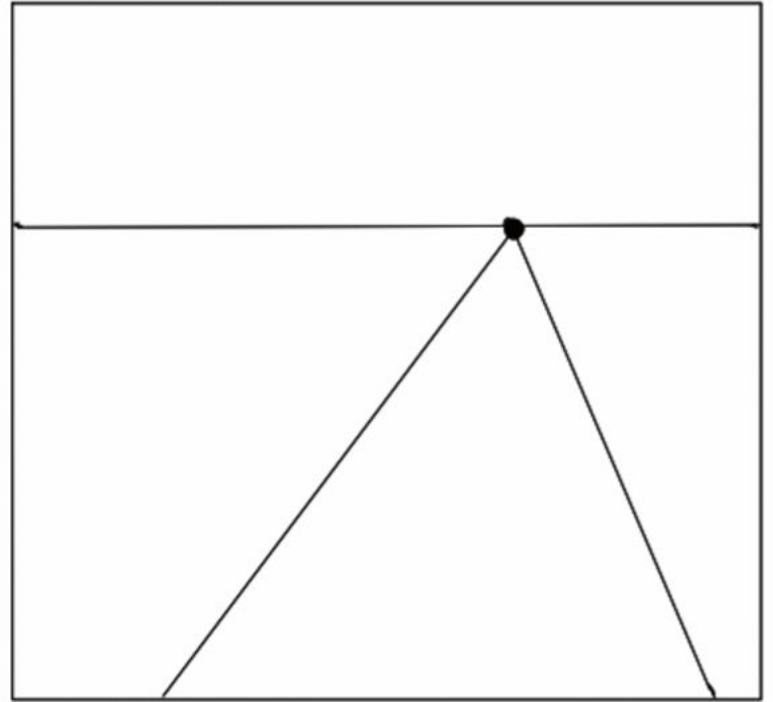

1) Draw your horizon line (line across your page) and your vanishing point (dot on horizon line). From the vanishing point, draw two lines.

Step 2

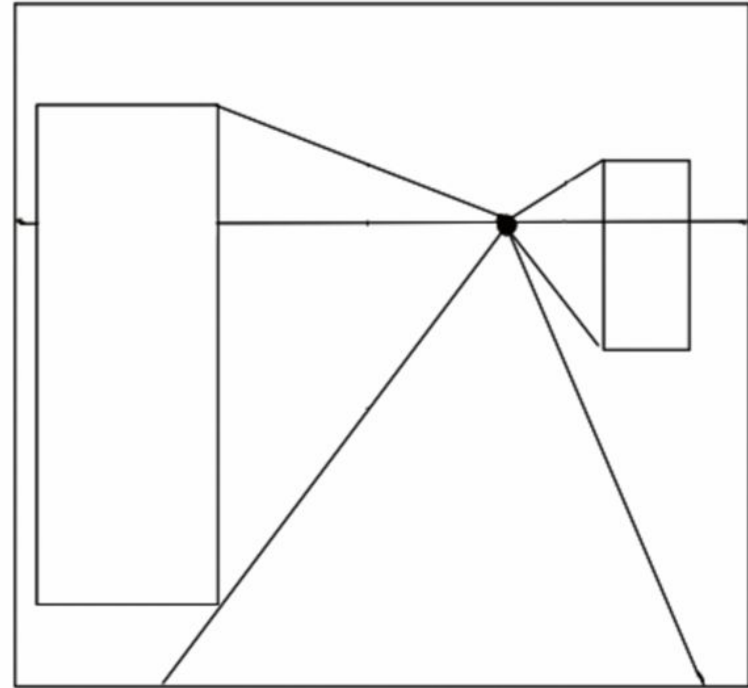

2) Draw your first building(s) by drawing a rectangle. Draw a line from the top corner and bottom corner to the vanishing point on your horizon line.

Step 3

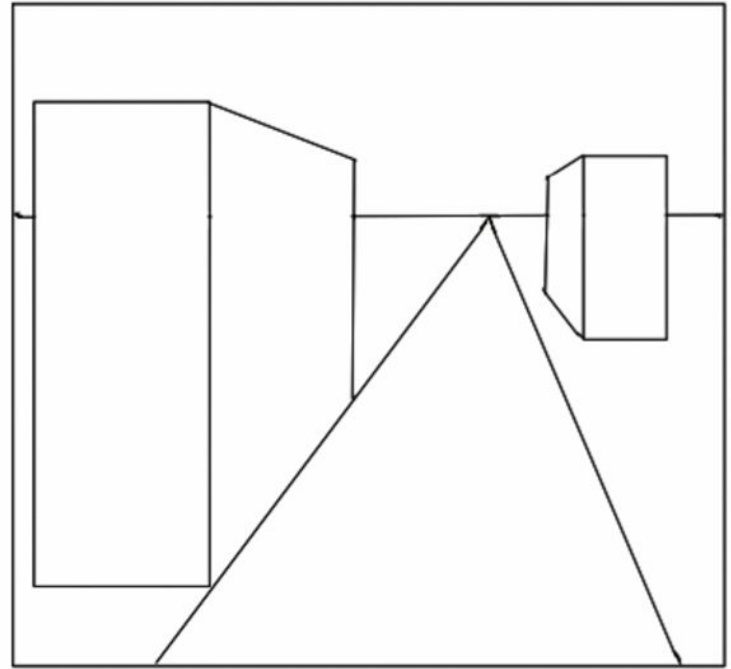

3) Add a second wall line and then erase any extra lines that extend to the vanishing point to complete the basic shapes of your buildings. This wall will be parallel to the front edge of your original rectangle.

Step 4



4) Add details to your foreground, middle ground, and background. Objects closer to the front will be larger, and as they move toward the background, they will become smaller.

Video Tutorial:

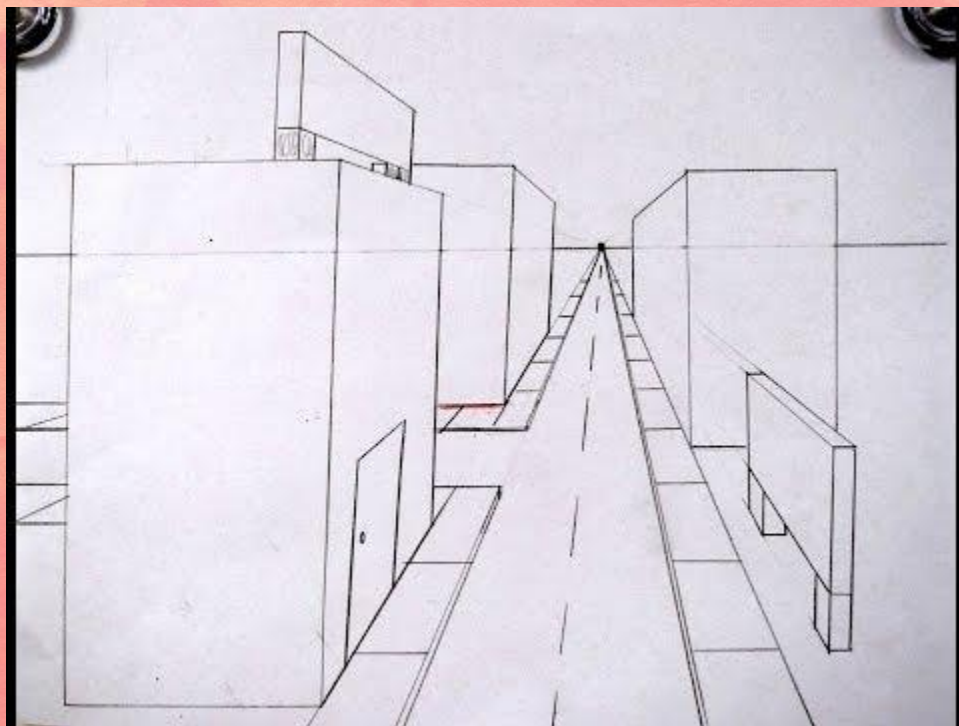

Examples

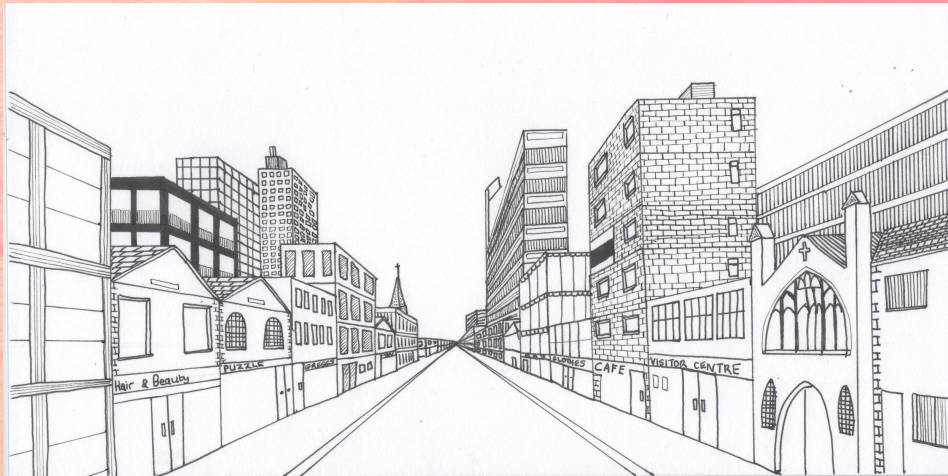

Good Copy

Once you have completed your rough copy and are comfortable with the technique, you are ready to start your good copy. Take your time and have fun!

Note: You do not have to colour this project, but shading is suggested.

Grade 7 Visual Art Rubric name: _____ 7-_____

Learning Goals:

I can apply the creative process to produce a piece of art.

I can demonstrate use of different art techniques as well as the Elements and Principles of Design

(ex: line, shape, texture, colour, shading, Unity, Harmony, Contrast, Repetition, Emphasis, and Proportion)

I can use my artistic techniques to create a mood or feeling in my work, or to communicate a big idea.

I can use the Critical Analysis Process to help me describe the strengths and weaknesses in my art.

Criteria	Level 1	Level 2	Level 3	Level 4
Technique	Struggles to use the artistic medium and technique effectively.	Good use of medium and technique, some minor problems.	Effective use of the artistic medium and technique.	Highly effective use of the artistic medium and technique.
Overall Aesthetic	Final piece needs significant polishing.	Work is neat but some elements need improvement.	Final piece is neat and attractive.	Work is highly polished and visually engaging.
Creativity	Work lacks creativity, effort and individuality.	Work could use further detail to make it unique.	Final piece is creative, original and unique.	Final piece is surprising and offers unique perspective on the subject.
Reflection	Struggles to apply critical analysis to own work.	Is able to communicate some feelings and ideas about own work.	Applies the critical analysis to own work, communicating ideas and feelings.	Excellent use of critical analysis to communicate feelings, ideas and understanding.